

## BEFORE YOU BEGIN

- Please read these instructions carefully to familiarize yourself with the required tools, materials, and installation sequences. Follow the sections that pertain to your particular installation. This will help you avoid costly mistakes. In addition to proper installation, read all operating and safety instructions.
- All information is based on the latest product information available at the time of publication. Kohler China Ltd. reserves the right to make changes in product characteristics, packaging, or availability at any time without notice.
- These instructions contain important care, cleaning, and warranty information-**please leave these instructions for the consumer.**

## 安装之前

- 请仔细阅读此说明书以熟悉所需要的工具、材料及安装顺序。遵循适合您的特定安装要求的各项内容，避免昂贵的损失。除了要正确安装外，还应阅读操作及安全说明。
- 所有的资料是按最新出版的产品资料编写而成。科勒中国有限公司保留任何时候无须通知即可改变产品特性、包装或产品可供类型的权利。
- 说明书包括重要的保养、清洁及担保方面的内容，请把这些资料交给用户阅读。

## PRODUCT REQUIREMENTS

### A. Summary Of Key Requirements

- Observe all local plumbing codes.
- Install the unit to a level subfloor.
- Provide properly-dimensioned framing.
- Baths are designed for a variety of installations, depending upon the model chosen.

## 产品要求

### A. 关键要求的总结

- 请遵守当地的卫生管道施工规范。
- 在水平的未装修地板上安装浴缸。
- 提供适当尺寸的结构。
- 浴缸的设计适用于不同的安装方式，请按型号来选定。

### B. Product Inspection

Uncrate and inspect bath for damage. Leave all materials in the crate during construction to prevent damage.

### B. 产品检查

小心地打开包装箱并检查浴缸是否损坏。施工期间将所有的材料都留在箱内，以防止损坏。

## ROUGHING-IN

- STUDIO K-11221T-W03/K-11221T-H-\*

### A. Ordering Information

Accessories/Hardware		
Drain	K-17295T-CP	Optional

## 安装尺寸

- 思都 K-11221T-W03/K-11221T-H-\*

### A. 订购信息

装饰/配件		
排水	K-17295T-CP	推荐使用

## B. Product Information

Fixture*	Basin area	Top area	Weight
Bathing well	1100×430mm	1540×640mm	42.3kg
	Water depth	Capacity	
To overflow	475-490mm	231L	

\* Approximate measurements for comparison only.

检修门尺寸: 450×400  
Access Size: 450×400

## C. Roughing-in

K-11221T-W03

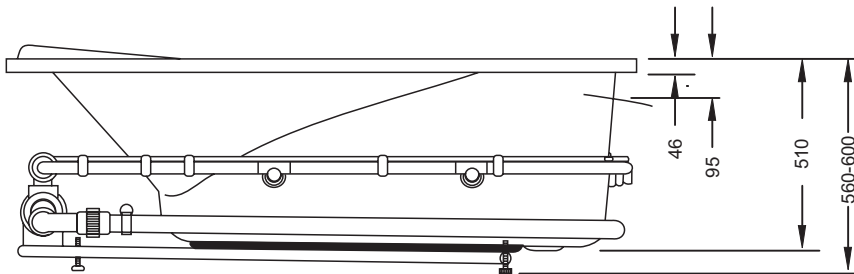
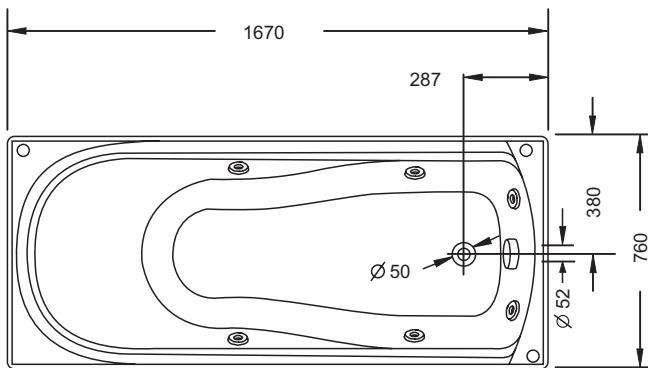

排水口: Ø50  
Diameter of drain hole: Ø50

溢水口: Ø52  
Diameter of overflow hole: Ø52

## • STUDIO K-555T/K-555T-H-\*

### A. Ordering Information

Accessories/Hardware		
Drain	K-17295T-CP	Optional

## B. Product Information

Fixture*	Basin area	Top area	Weight
Bathing well	955×430mm	1392×635mm	39kg
	Water depth	Capacity	
To overflow	475-490mm	212L	

\* Approximate measurements for comparison only.

检修门尺寸: 610×410  
Access Size: 610×410

1039290-T01-E

## B. 产品资料

浴缸	底部	顶边	重量
面积	1100×430毫米	1540×640毫米	42.3公斤
	深度	容积	
到溢水口	475-490毫米	231升	

\*为比较浴缸所用的参考数值。

## C. 尺寸图

UNIT: mm  
单位: 毫米

K-11221T-H-\*

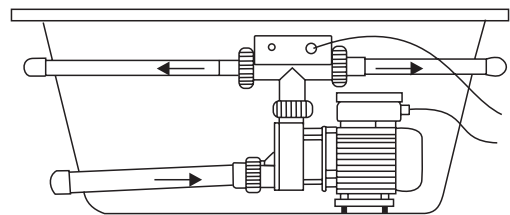

## • 思都 K-555T/K-555T-H-\*

### A. 订购信息

装饰/配件		
排水	K-17295T-CP	推荐使用

## B. 产品资料

浴缸	底部	顶边	重量
面积	955×430毫米	1392×635毫米	39公斤
	深度	容积	
到溢水口	475-490毫米	212升	

\*为比较浴缸所用的参考数值。

### C. Roughing-in

### C. 尺寸图

UNIT: mm  
单位: 毫米

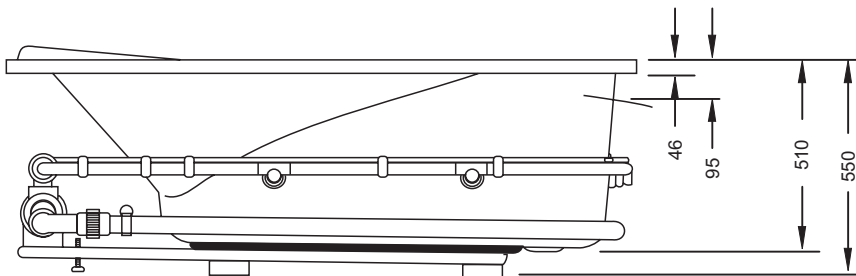
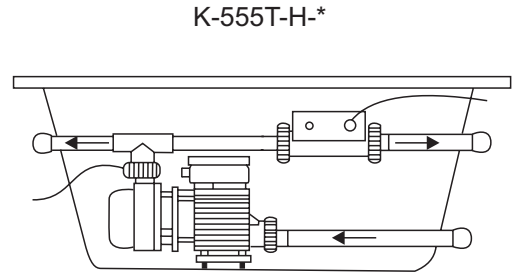
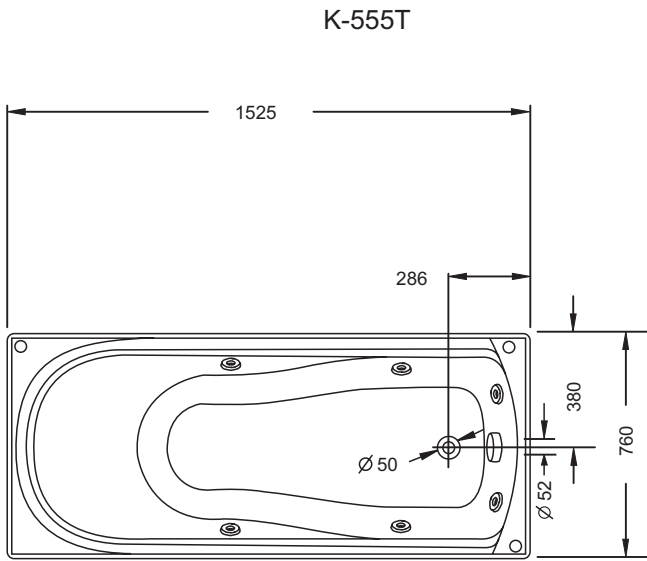

排水口: Ø50  
Diameter of drain hole: Ø50

溢水口: Ø52  
Diameter of overflow hole: Ø52

## INSTALLATION REQUIREMENTS

## 安装要求

### A. Tools Required B. Materials Required

- |                                                                                                                                                                                                                                                   |                                                                                                                                                                                                                                                                                    |
|---------------------------------------------------------------------------------------------------------------------------------------------------------------------------------------------------------------------------------------------------|------------------------------------------------------------------------------------------------------------------------------------------------------------------------------------------------------------------------------------------------------------------------------------|
| <ul style="list-style-type: none"> <li>• Adjustable pipe wrench</li> <li>• Rule</li> <li>• Level</li> <li>• Safety shoes</li> <li>• Safety glasses</li> <li>• Square</li> <li>• Screwdriver</li> <li>• Pliers</li> <li>• Utility knife</li> </ul> | <ul style="list-style-type: none"> <li>• Plumbers putty</li> <li>• Wall coverings, as necessary</li> <li>• Silicone sealant</li> <li>• Gypsum cement (optional)</li> <li>• Construction adhesive (optional)</li> <li>• Protective covering for bathtub</li> <li>• Nails</li> </ul> |
|---------------------------------------------------------------------------------------------------------------------------------------------------------------------------------------------------------------------------------------------------|------------------------------------------------------------------------------------------------------------------------------------------------------------------------------------------------------------------------------------------------------------------------------------|

### A. 所需工具

- 管道扳手
- 刻度尺
- 水平仪
- 安全鞋
- 安全眼镜
- 直角尺
- 螺丝刀
- 钳子
- 多用工具刀

### B. 所需材料

- 管道用油灰
- 墙面保护罩(如需要)
- 密封硅胶
- 石灰水泥(选用)
- 建筑粘胶(选用)
- 浴缸保护套
- 钉子

### C. Clearance Requirements

Check the rough-in and room dimensions to provide adequate available space for the bath unit.

### C. 预留尺寸

检查安装尺寸及浴室尺寸，确保有充分的空间安装浴缸。

**A. Old Bath Removal**

Disconnect the drain at the trap. Remove the old wall material. Slip boards under the old bath feet to protect the floor, and slide the old bath out of the recess as illustrated.

**A. 拆除旧浴缸**

在存水弯处拆下排水管。清除所有旧墙材料。在旧浴缸下面塞入护板以保护地面，并按如图所示把旧浴缸从安装空间拉出。

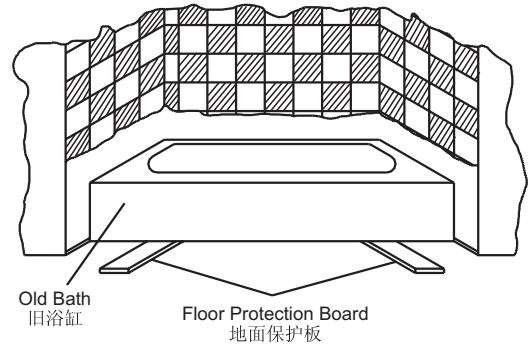

**B. Subfloor Preparation**

Check the flooring under the bath, and make repairs as needed. Make sure the subfloor is level.

**B. 底层地板的准备**

检查浴缸下的地板，若需要请进行修补。请确保底层地板水平。

**C. Bath Area Construction preparation**

Possible framing arrangements are illustrated below. Use the framing construction appropriate for your particular bath model. Some modifications may be needed for other types of construction, if preferred.

**C. 浴缸支撑结构的准备**

下图所示为几种常用的支撑结构，请采用适合您的浴缸型号的结构。对不同的支撑结构方式，也许有必要进行适度调整。

**• Recommended For Drop-in Models**

**1). Corner Installation**

The suggested framing construction is illustrated.

**1). 墙角安装**

右图为建议的支撑结构。

**• 下列建议适合为无裙边浴缸使用**

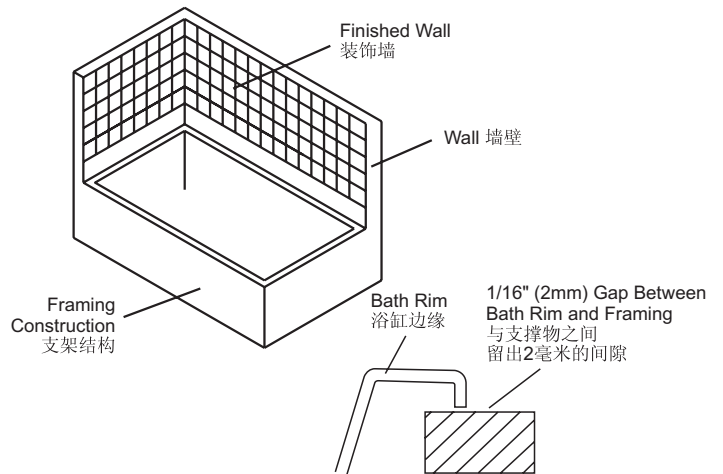

**2). Recess Installation**

The suggested framing construction is illustrated.

**2). 三面靠墙安装**

建议的三面墙环围的支撑结构如图所示。

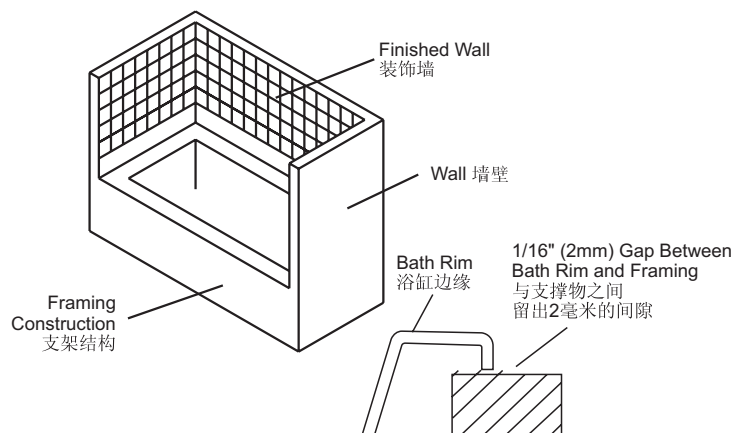

### 3). Peninsular Installation

The suggested framing construction is illustrated.

### 3). 单面靠墙安装

建议的单面墙支撑结构如图所示。

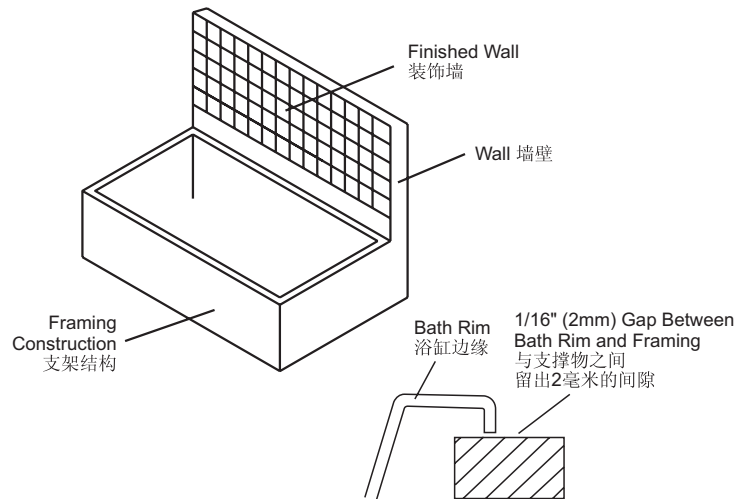

## D. Plumbing Preparation

Position the plumbing according to rough-in dimensions. Cap the supplies and check for leaks.

## D. 管道的准备

将管道按安装尺寸安置，堵塞供水管并检查是否漏水。

## BEFORE INSTALLING UNIT

**A.** Your new bath has been manufactured to the highest possible standards. However please inspect for any possible damage that may have occurred in transit. **NOTE:** Warranty does not cover damage to bath caused in transit or installation.

**B.** The protective film original covering your spa has been removed to fit its equipment, therefore, carefully protect its surface during installation.

**C. Partially Install Bath Drain**  
Install the drain on the bath according to the drain manufacturer's instructions. Carefully pass the waste (drain) fitting between the spa pipes and bathtub wall.

## 安装之前

**A.** 本浴缸质量上乘。但在搬运过程中，可能会遭到损坏。请仔细检查。

**注意：**搬运或安装过程中所造成的损坏，不能获得保修。

**B.** 为了安装原先盖在按摩浴缸上的塑料保护膜已除去。因此在安装过程中注意保护浴缸的表面。

**C. 局部安装浴缸排水配件**  
按照厂家说明书，把排水配件部分安装在浴缸上。小心地将排水管件穿过按摩系统管件及浴缸外壁。

## INSTALL BATH

1) Your new Hydrotherapy Massage Spa has been manufactured to the highest possible standards, it has been factory tested and approved.

2) When removing bath from protective carton **DO NOT LIFT BATH BY PIPE WORK.** Inspect for any possible damage that may have occurred in transit.

## 安装浴缸

1) 本浴缸质量上乘，已经工厂检测通过。

2) 从起保护作用的纸箱中取出时，请不要拎着管道部分将浴缸取出。检查可能有搬运造成的损伤。

3) Identify motor access location before proceeding with installation.

**NOTE: NO MOTOR ACCESS NO WARRANTY SERVICE.** Ventilation must be provided in order to allow heat from motor to dissipate.

3) 安装前，请找到马达检修门的位置。  
注意：无马达维修口，不能获得保修。应通风良好，保证马达散热。  
请根据你的实际情况预留检修门。

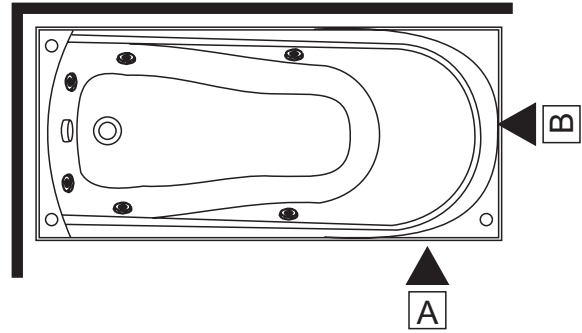

**PROVIDE MOTOR ACCESS AS SHOWN:**

如图所示马达检修门位置。

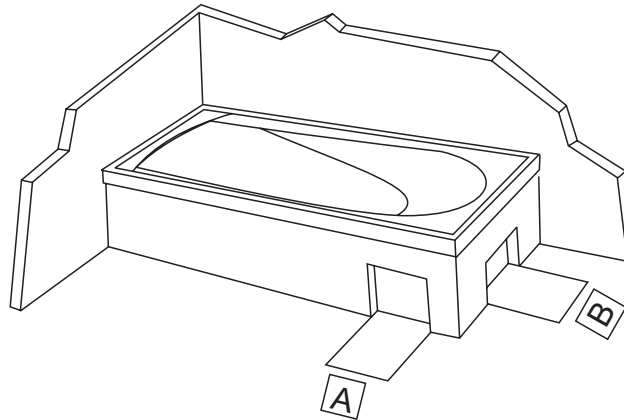

4) Ensure adjustable feet are fitted through holes drilled in support frame.(only available for K-11221T-W03/K-11221T-H-\*)

4) 确保通过支架上所钻的孔，将可调支脚安装好。  
(此条仅适用于K-11221T-W03/K-11221T-H-\*)

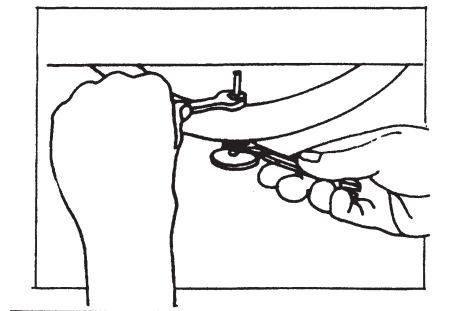

5a) Locate bath in proposed position.  
The protective film originally covering your spa has been removed to fit its equipment, therefore, carefully protect its surface during installation.

5a) 将浴缸放入建议的位置。  
为了便于安装，原先盖在按摩浴缸上的塑料保护膜已除去。因此在安装过程中注意保护浴缸的表面。

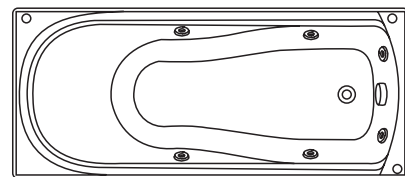

5b) **IMPORTANT:** Bath must be installed level on all top edges.

5b) 注意：浴缸必须水平地放置。

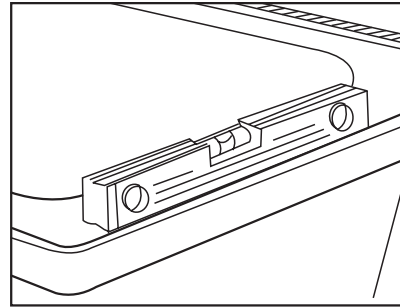

5c) Adjust and lock feet to recommended height.

5c) 将支脚调节并固定在建议的高度位置。

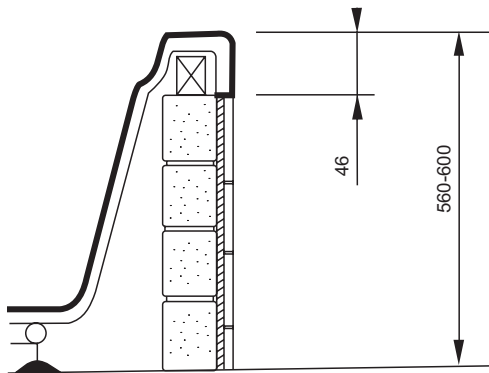

**K-11221T-W03/K-11221T-H-\***

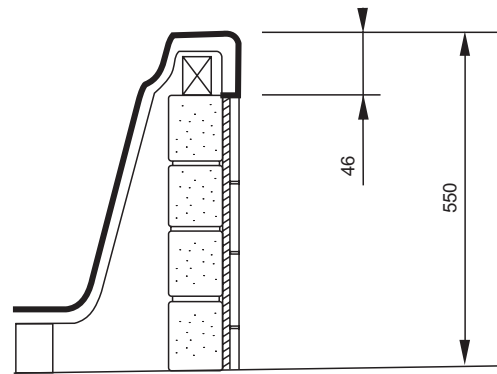

**K-555T/K-555T-H-\***

6) Fit timber batten supports or check into wall where necessary. See diagrams below for typical installation with tiled walls.

Floor should be flat, level and free of any bumps and protrusions. Ensure support feet are fully supported.

6) 将木条嵌入需要做支撑或衬垫的墙体中，下图可供典型瓷砖墙面的安装参考。

地面必须水平、平整。确保支撑脚得到完全支撑。

**A. Base Support**

**A. 底部支撑**

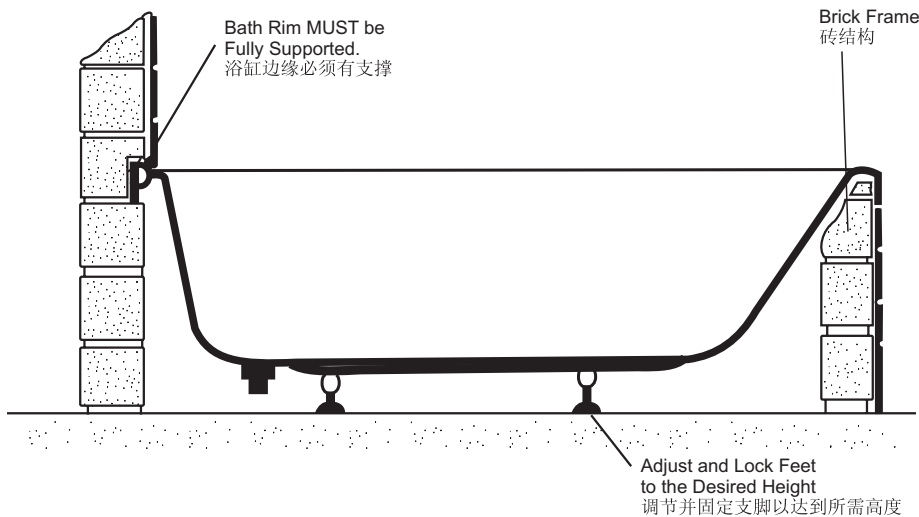

**Only available to K-11221T-W03/K-11221T-H-\***  
 仅适用于K-11221T-W03/K-11221T-H-\*

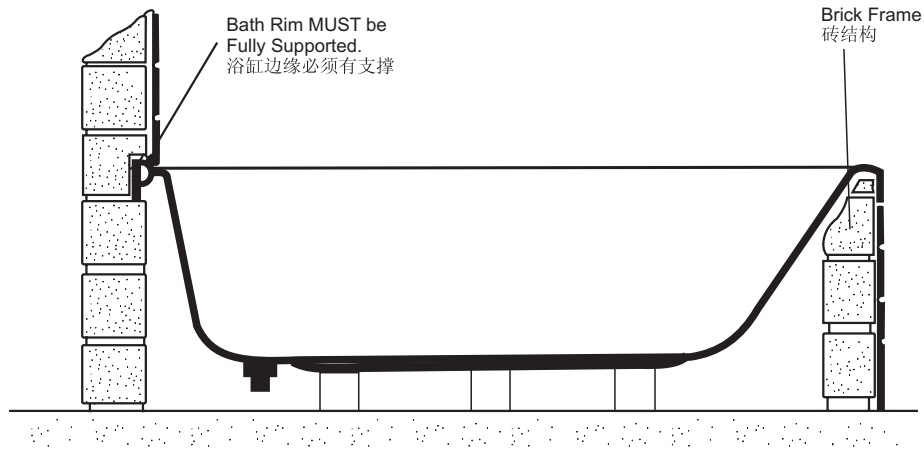

Only available to K-555T/K-555T-H\*  
 仅适用于K-555T/K-555T-H\*

## B. Bath Rim Support

Drop-In Models:

**CAUTION:** Risk of product damage. Do not support the weight of the bath by the rim.

After the bath is securely positioned and bath rim well supported, please complete step 7). Install the plumbing and thoroughly check the unit for leaks. When you are satisfied with the result, proceed with step (1) and step (2) below.

(1). Install the ceramic or marble tiles. Seal the joints between the bath rim and the finished tiled wall using silicone sealant. RTV (Room Temperature Vulcanizing) sealant is recommended.

(2). For sunken type installation, construct the ceramic or marble tiles. Seal the joints between the bath rim and the tiled wall with silicone sealant.

## B. 完成浴缸边缘处的安装

无裙边浴缸类型:

**注意！！** 当心损坏浴缸！不要靠浴缸边缘支撑浴缸的重量。

在浴缸安放到位并且浴缸边缘得到完全支撑的情况下完成步骤7)。安装卫生管道并检查排水是否有渗漏。检查通过后才开始以下(1)、(2)步骤。

(1). 安装墙壁贴面(如瓷砖或大理石)。用硅胶密封浴缸边缘和贴面的连接处。建议使用常温下硬化的密封胶。注意：为了有最佳的防水效果，建议将防水边处敷上瓷砖密封。

(2). 对嵌入式安装，在敷上瓷砖或大理石贴面后，再用硅胶密封浴缸边缘和贴面的连接处。

Rebated Into Wall

嵌接式

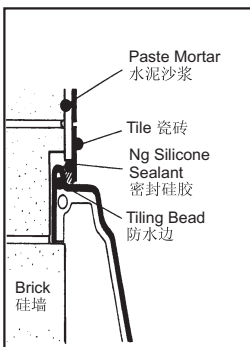

Packed Out From Wall

入墙式

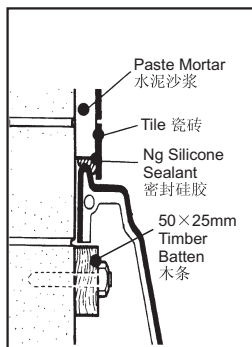

Under Flange Tiling

砖托式

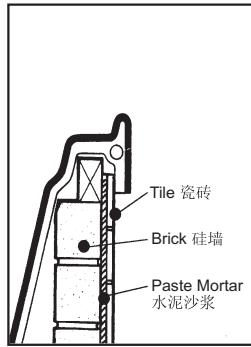

Hob Mount Tiling

架砖式

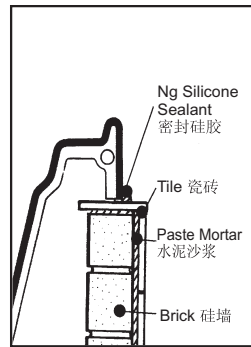

Flush Front Tiling

前平式

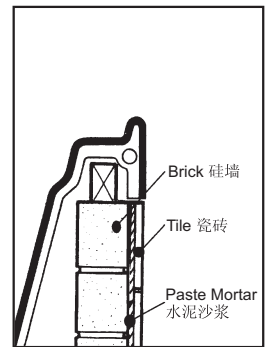

### 7) Install Plumbing

**CAUTION:** Risk of damage to bath bottom and subfloor, Ensure a watertight seal on the bath drain connections.

(1). When the bath is securely positioned, connect the drain to the trap.

**NOTE: An access panel will simplify future maintenance.**

(2). Install the faucet valving and spout tee. When drilling bathtub for faucet, ensure sufficient clearance to avoid brick support wall. Open the hot and cold water valves and check the supply connections for leaks.

(3). Run water into the bath and check the drain connections for leaks.

(4). Fill the bathtub up to the overflow level and check overflow unit for leaks.

### 7) 安装卫生管道

**注意！！** 避免损坏浴缸底部和底层地面。浴缸的所有排水接口都要确保做防渗密封。

(1). 当浴缸固定到位后，将排水管与存水弯相接。

注意：为方便以后维修，一定要安装一个检修门。

(2). 安装水龙头阀门及喷头三通。在浴缸上钻孔安装龙头时，请保证留有足够的间距，避免触及支撑框架。打开冷水及热水阀门，检查所有给水管接头是否渗漏。

(3). 将浴缸注入水，检查排水配件接头是否有渗漏。

(4). 注水至溢水口高度，检查溢水组件是否有渗漏。

8) Connect power supply (220V/50Hz, 10A) to motor. This should be a separate line, direct from the switchboard.

Connect power supply (220V/50Hz, 10A) to heater. This should be a separate line, direct from the switchboard.

The electrical connections must comply with local authority regulations and must be done by an authorized electrician. Please refer to Spa Pump Installation & Operation Instructions sheet.

8) 将水泵连接到额定电压为220V/50Hz，额定电流为10A的供电线路上，这根电源线应该是单独的从开关箱上接出。

将加热器连接到额定电压为220V/50Hz，额定电流为10A的供电线路上，这根电源线应该是单独的从开关箱上接出。

电气连接必须由授权电工来完成，操作必须符合当地电气规范。请按照按摩水泵系统安装说明及操作手册来安装。

9) Fill bathtub with water to approximately 40 mm above the jets and trial run pump for 10-15 minutes. Check all the fittings for leaks and test the control functions. Switch off the spa pump and leave the unit filled with water (pump is not running) for at least another two minutes. Check the pump and pipes union connections for leaks. Hand tighten union connections if required.

9) 将浴缸注入水，水位高过喷头大约40mm，试运行水泵10-15分钟。检查所有的部件是否有渗漏并测试控制系统。关闭按摩水泵并让浴缸注满水(水泵不运行)至少2分钟。检查水管连接处是否有渗漏。如有必要的话将各接头处再拧紧。

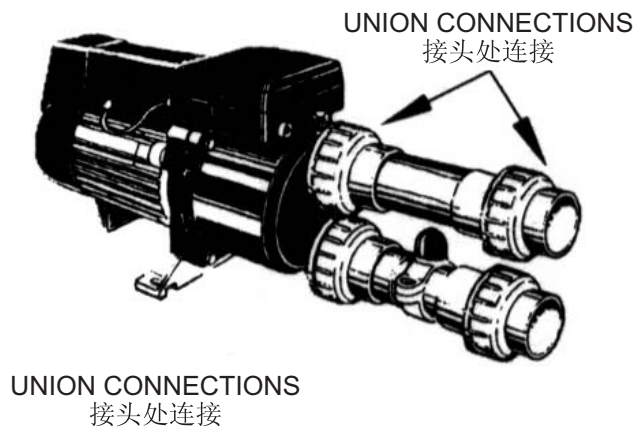

**IMPORTANT:** Your spa has been factory tested and approved. It is the responsibility of the installer to test run the spa check all the fittings for leaks and test the control functions.  
NON OBSERVANCE WILL INVALIDATE FACTORY WARRANTY.

**重要信息:** 按摩浴缸已经工厂检测通过。安装人员在负责检查按摩浴缸的工作情况, 检查所有安装有无渗漏。检查控制功能。疏忽导致的损坏, 不能获得工厂的保修。

## DRILLING AND CUTTING ACRYLIC

## 在亚克力表面上钻孔和切割

**DRILLING:** Small holes can be drilled with a twist drill, but the cutting edge **MUST** be backed off with an oil stone (the sharp edge dulled). Large holes must be drilled with a hole saw. Maximum drill size-12mm. Drill speeds-6mm x 1800 RPM-12 mm x 900 RPM.

**NOTE:** Always drill from acrylic surface.

**CUTTING:** If for any reason the acrylic requires cutting, use a fine tooth hacksaw and proceed with caution. Edges can be smoothed with a second-cut file and medium-fine sandpaper. If the surface of the acrylic should happen to be damaged, it can be restored by polishing with an abrasive cleaner. Deep scratches can be removed by rubbing with 600 grade wet & dry sandpaper then polishing.

**钻孔:** 可用一麻花钻头钻小孔, 但切削刃必须用一块油石磨钝。大孔须用孔钻加工。麻花钻头的最大尺寸为12mm, 速度为6mmx1800转/分至12mmx900转/分。

**注意:** 钻孔要从亚克力表面钻向浴缸背面。

**切割:** 如果因故需要切割亚克力, 请用优质齿型钢锯仔细切割。边缘可用一旧锉刀及中等砂纸磨平。如果亚克力表面受损, 可用磨蚀性清洁剂抛光, 将其恢复。深度刮伤可用600号水砂纸磨平, 然后抛光。

## CLEAN-UP AFTER INSTALLATION

## 完工清理

When cleaning up after installation, do not use abrasive cleansers as they may scratch and dull the surface. Use warm water and liquid, non-abrasive detergent to clean the surface.

Stubborn stains, paint, or tar can be removed with mineral spirits. Do not use cleaners containing solvent. Plaster can be removed by scraping with wood edge. Do not use metal scrapers, wire brushes, or other metal tools. One of the powder type detergents may be used on a damp cloth to provide mild abrasive action to the residual plaster.

在安装完成后进行清理时, 请勿使用磨损性的清洁用具, 以免擦伤浴缸表面, 使其失去光泽。使用温水和非磨损性的液体清洁剂, 清洗浴缸表面。

难以清除的污迹、油漆、或柏油, 可用酒精擦净。请不要让含有溶剂的清洁剂。滞留水泥可用薄木刀刮掉。请不要使用金属刮刀, 钢丝刷, 或其它金属工具。对残留的水泥浆, 可用湿布粘些洗衣粉, 以提供轻微的研磨作用。

## IMPORTANT CONSUMER INFORMATION

## 重要的用户资料

### A. Consumer Responsibilities

**Cleaning Acrylic Surfaces:** Do not use abrasive cleansers on any acrylic surfaces, as they will scratch and dull the surface. Wipe out the bath after each use to prevent a build-up of soap and scum.

If the acrylic surface becomes dull, an automotive type rubbing compound \*may be used on the unit, followed by an application of paste wax.

\*We recommended:

Rubbing compound mequiars mirror glaze 28 metal polish (import product) or "green oil".

### A. 用户的责任

**清洗亚克力表面:** 请勿在亚克力表面使用磨损性的清洁用具, 以免擦伤浴缸表面, 使其失去光泽。每次使用后, 将浴缸擦干, 以防止肥皂和污垢沉积。

若亚克力表面失去光泽, 先用汽车抛光剂\*, 然后再用粗腊打亮。

\*我们推荐使用以下2种抛光剂:

- ① Mequiars 镜面光亮28金属上光剂。(进口)
- ② 抛光膏(绿油)。

## REQUESTING SERVICE

## 售后服务

Please take a moment to familiarize yourself with the Kohler warranty, its benefits, and limitations. Here is what you need to do if you require service:

**FIRST:** Contact the dealer or contractor who sold and installed the product. They should be able to solve any problems you may have.

**SECOND:** If your dealer or contractor cannot solve the problem, they will contact or supply you with the name of the local Kohler Distributor.

**THIRD:** If you are unable to obtain the warranty service through either your contractor or Kohler China Ltd. distributor, please write us directly:

Central Customer Service Center  
Kohler China Ltd.  
19/F, Shanghai Square,  
138 Huaihai Road, Luwan District  
Shanghai, PRC, Post Code: 200021

**FOURTH:** Include all pertinent information regarding your claim, including a complete description of the product, model numbers, colors, finishes, and the date the product was installed. Include a description of the problem, and a photocopy of your invoice for the products involved. Also give us the name of the contractor and distributor.

请抽出一些时间来了解科勒的担保，权益，及限制。当您需服务帮助时，请按下列步骤联系：

第一：与产品的销售者，或安装承建者联系。他们应该能够解决您所遇到的问题。

第二：如果您的产品销售者，或安装承建者解决不了问题，他们将和科勒的经销商或技术专家联系，或提供他们的名字。

第三：如果您无法得到安装承建者或科勒中国有限公司的经销商的担保服务，请直接写信给：

上海市卢湾区淮海中路138号  
上海广场19楼  
邮编：200021  
科勒中国有限公司  
中央客户服务中心

第四：请将与您申报有关的资料全部寄来，包括完整的产品名称，型号，颜色，表面处理和产品的安装日期。同时附带描述问题产生的情形，以及所涉及产品的购货发票复印件。另外，再提供您的安装承建者或经销商的名字。

## LIMITED ONE-YEAR WARRANTY

## 一年有限担保

### Plumbing Fixtures and Fittings Limited One-year Warranty

Kohler plumbing fixtures and fittings are warranted to be free of manufacturing defects.

This product is warranted for one year from date of purchase. Kohler China will be responsible for any problems caused by manufacturing defects provided with the invoice. Kohler China will, at its election, repair, replace or make appropriate adjustment where Kohler China inspection discloses any such defects occurring in normal usage within one year after purchase.

Implied warranties including that of merchantability and fitness for a particular purpose are expressly limited in duration to the duration of this warranty, Kohler China disclaims any liability for special, incidental or consequential damages. Damages to the product caused by misuse, abuse and installation that is not in accordance with the owner's manual are not covered by this warranty.

To obtain quick warranty service, please contact your dealer, or write to Kohler China. (Original sales receipt must be provided as the proof of purchase.)

Kohler China Investment Company Ltd.  
Central Customer Service Center  
19/F, Shanghai Square, 138 Huai Hai  
Road, Luwan District, Shanghai, PRC  
Zip Code: 200021

This is our exclusive written warranty.

### 陶瓷及浴缸产品及配件担保——一年有限担保

科勒公司担保其陶瓷及浴缸产品及配件在制造工艺上无瑕疵。

本产品自购买之日起即获得本公司一年的质量保证。在质保期内，凭购货发票，科勒公司将免费承担由制造质量引起的任何问题。经核查后，科勒中国有限公司有权决定是修理、更换、还是作适当的调整。

这里所指的担保，包括产品，都已明确地限制在该担保期之内。科勒中国有限公司对其后出现的损坏不负有任何责任。担保也不包括外观损伤、使用不当以及未按说明书安装的损失。

为获得快捷的担保服务，请联系您的销售商；您也可写信给科勒中国有限公司(请出示销售发票原件作为购货凭证)：

科勒(中国)投资有限公司  
中央客户服务中心  
上海市卢湾区淮海中路138号  
上海广场19楼  
邮编：200021

这是我们全部的书面担保。